

Secure & Connected Print & Apply Labelling Solutions

COBALT NEXUS

Built to last and perform in the most demanding environment. Backed by a comprehensive 3 year warranty.

- Compliant to GS1 international barcode labelling standards
- Integrated Sentinel with 100% barcode quality assurance
- Incorporation of 2D matrix codes for traceability in manufacture
- User friendly full colour touch screen HMI
- Cobalt Print Manager on board for networked or standalone operation
- Minimal user intervention
- Remote access for diagnostics and support, direct from Cobalt Technical services, facilitating a range of managed services
- Label optimisation to keep media costs as low as possible without compromise of the GS1 standard
- Specified by experts for the best return on investment
- Designed, built, tested, installed and commissioned to your exact requirement

COBALT
SYSTEMS

COBALT NEXUS

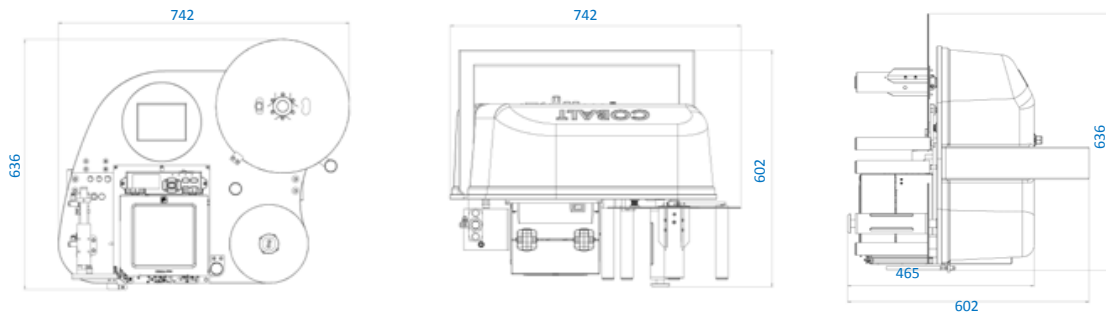

Nexus Configuration	Case/Pack labelled per min
High Speed Application	80
Automatic Variable Reach	40

High Speed Application



80

Automatic Variable Reach



40

Technical Specifications

- **Electrical supply** – 220/240 volts single phase AC 50Hz 5amp
- **Compressed air supply** – Max 6 bar, 120 litres per minute
- **Weight** – 45kg
- **Connectivity** – 10/100 Ethernet cat5, Serial RS232, USB 2.0, local printing via USB memory drive, external port for PC-less firmware updates, additional ethernet port for remote access support, Sentinel onboard ethernet & 15 pin D type connections for verification and validation modules
- **Display** – Rotational LED colour touch screen, maintenance service indicator, multi-language selection
- **Label reel** – max 170mm wide, 320mm OD, 76mm core ID
- **Label** – max 168mm wide, 400mm long
- **Print width** – max 168mm
- **Print speed** – max 305mm per second
- **Print technology** – Thermal Transfer Ribbon & Direct Thermal
- **Print resolution** – 203 & 300 dpi
- **Smart reach application** – Variable reach up to 500mm for side of case labelling
- **No contact application** – Blow apply 5mm from surface

Options

- **Floor stands** – H base 1.8M bespoke
- **Position adjustment** – Height, reach, height & reach, position indicator, power adjust, pneumatic adjust
- **Status beacon** – 2 to 6 light plus audible alarm
- **Sensor Pack** – Label on pad, air pressure, variable reach control, low label reel
- **Advanced rewind spindle** – push button collapsing fins for easy liner release
- **Remote access support** – VPN or 3G
- **Label & Seal** – Integrated tape sealer, choice of sealer brands
- **Sentinel** – On-board barcode verification before application, barcode validation after application
- **Industrial PC** – 15" HD colour graphics touch screen, Sentinel result logging & peripheral management
- **Alternative configurations** - High speed side for shrink wrap packs, high speed front for shrink wrap packs, standard & extended reach for front of cases, dual action for front & side of cases & GS1 pallet front & side, dual head continuous operation, triple head continuous operation